

 <b>Lvwo</b>	<b>Specification</b>	Versions	
		Date	
		DOC No:	
Address: Address: Economic Development Zone of Hangbu town, Shucheng County, Lu'an City, Anhui Province, China.			
Tel:+86-0564-8030526	Post Code:231300	Web: <a href="http://www.lvwo-energy.com">www.lvwo-energy.com</a>	

# 720KW/1.49MWh

## Technical Project for Mobile Energy Storage System

<b>Prepared By</b>	<b>Checked By</b>	<b>Approved By</b>
Zhang Hongjiang	Zhou Youbing	Li Pai

<b>Customer Approved</b>	<b>Signature:</b>
	<b>Date:</b>
	<b>CompanyName: (Company Stamp)</b>

 <b>Lvwo</b>	<b>Specification</b>	<b>Versions</b>	
		<b>Date</b>	
		<b>DOC No:</b>	
<b>Address: Address: Economic Development Zone of Hangbu town, Shucheng County, Lu'an City, Anhui Province, China.</b>			
<b>Tel:+86-0564-8030526</b>	<b>Post Code:231300</b>	<b>Web: www.lvwo-energy.com</b>	

# Content

一、	Project Overview .....	1
二、	Energy Storage System Configuration List .....	1
三、	Mobile Charging System Project .....	4
3.1.	Components of the System .....	4
3.2.	System Configuration .....	5
3.3.	Equipment Layout .....	7
四、	Introduction to the Main Equipment of the Mobile Charging System .....	8
4.1.	Battery System .....	8
4.2.	Vehicle Charging Pile .....	13
4.3.	PCS Parameter .....	17
4.4.	Thermal Management System .....	18
4.5.	BMS .....	21
4.6.	Fire-fighting System .....	32
4.7.	System Communication Topology Diagram .....	35

## 一、 Project Overview

This mobile energy storage charging system is dispatched by a 20'GP trailer with a trailer head, with strong mobility to rescue broken-down pure electric vehicles, the system can realize unattended automatic switching of working modes according to the preset AC limit, AC priority and DC priority modes are optional. It is be equipped with high degree of intelligence. System status, video system realizes remote supervision, and uses AC/DC input, DC output charging piles. Compatible with AC/DC input sources, the charging system can be output by battery system and also can be used as a fixed pile. The 720KW/1.54MWh mobile charging system is configured with one 20'GP rack per system and the required number of trailer heads is based on user-side utilization.

Each 720KW/1.49MWh system adopts a centralized design scheme. Each battery prefabrication module consists of 8 sets of 691.2V high-voltage battery clusters, 1 set of thermal management system, 1 set of fire-fighting system, 1 set of monitoring system, 1 set of lighting system, 2 DC convergence control cabinets, and 2 sets of 360KW dual-gun charging piles, 2 sets of 400KW-PCS, all integrated into a 20'GP container.

## 二、 Energy Storage System Configuration List

Table 720KW/1.49MWh Energy Storage System Equipment List

<b>720KW/1.49MWh Configuration List</b>					
<b>NO.</b>	<b>Equipment Name</b>	<b>Specification parameter</b>	<b>Quantity</b>	<b>Unit</b>	<b>Notes</b>
<b>1</b>	Energy storage battery prefabricated cabin	720KW/1.49MWh	<b>1</b>	Set	For each set of sub-items, please refer to 1.1 to 1.13.
1.1	Battery cluster	15AH-18P216S, nominal power 373.248kWh	4	Cluster	
1.1.1	Battery module	15AH-18P24S 20.736kWh	9	Set	
1.1.2	Cell	3.2v15A cell	3888	Pieces	A Cluster Battery Consumption
1.2	High voltage box	High voltage box	4	Set	1 set of controls and 2 branch circuits

1.3	Thermal management system	3KW air conditioner	4	Set	
1.4	Fire-fighting system	Perfluoroacetone fire extinguishing equipment	1	Set	
1.5	Converging cabinet	4 In and 1 out	2	Set	
1.6	BMS	1 BAU, 8 BCU and 72 BMU	1	Set	University of Science and Technology of China
1.7	Control system	Battery compartment, and electrical compartment surveillance camera	1	Set	
1.8	Power cabinet	Provision of power distribution for auxiliary systems in container	1	Set	
1.9	In-cabin cables	/	1	Set	
1.10	Energy storage converter	Rated power 100kW, AC output 400V/50Hz, DC input range 600-900V, three-phase and four-wire, without isolation transformer.	8	Set	
1.11	Charging pile	360KW dual-gun	2	Set	
1.12	Container	20'GP	1	Set	
1.13	Bracket	20'GP	1	Set	
2	Trailer truck	/	1	Set	Options according to the actual needs of the user side.

A new generation of energy storage system solution project with a standardized modular design solution is equipped with high energy density, safety, maintainability, flexibility, service life and efficiency. At the same time, it reduces energy consumption, costs and land area.

(1) Cell

It adopts high-capacity lithium iron phosphate batteries with a cell capacity of 15Ah. The cycle times of the battery system are not less than 6000 times, and the calendar life is not less than 10 years. And, the cells, modules and clusters have passed the GB/T36276-2018 type test, and the performance and safety of the system are guaranteed.

(2) The system design is equipped with fuses for battery clusters, and the contactors are selected according to higher current-carrying level to meet the higher load cut-off life; the convergence cabinet is equipped with load switches + fuses for multi-level system protection to ensure the safety of the battery. Perfect quadrant warning and protection mechanism, alarm, power limit, protection of the three-level control and protection strategy, to ensure the ultimate operation safety of the system.

(3) Fire-fighting system is equipped with perfluorohexanone fire-fighting system and fire detectors to establish an early warning and disposal system for battery abnormality to enhance battery safety. It is also equipped with active ventilation and explosion-proof valve design to ensure personal safety.

(4) BMS system utilizes three-level BMS design, no parallel connection of battery cells, and BMS can accurately collect the voltage of each battery cell. BMS has single cluster management function, capable of independent charging and discharging, with reliable single cluster fault exit function. And BMS also has the ability of inter-cluster equalization, which can effectively reduce the impact of inter-cluster loop current on the system. It has good comprehensive performance.

(5) Thermal management project considers that most of the electrical energy loss during the operation of the system equipment and batteries will be dissipated in the form of heat. Therefore, the energy storage system uses four sets of 3KW wall-mounted air conditioners, which are designed to meet the special requirements of temperature control and installation space for energy storage batteries, adopting an integrated structure, built-in installation, side air outflow on the condensing side that is closer to the heat source, with a high specific heat capacity, a compact structure, low noise, and a fast response speed, providing safe, reliable, energy-efficient, and precise temperature control for the energy storage system. And, the heating function ensures that the energy storage system can be operated in a low-temperature environment, guarantees that the temperature of each cell of the energy storage system is uniform and maintains an optimal operating environment, ensuring the performance of each cell is consistent, and reducing the annual capacity degradation rate of the batteries.

(6) Installation and application of non-walk-in battery prefabricated cabin system design, side door opening, easy installation and maintenance, higher overall energy density, and small footprint. Battery compartment adopts integrated integration method, overall lifting and

 <b>Lvwo</b>	<b>Specification</b>	Versions	
		Date	
		DOC No:	
Address: Address: Economic Development Zone of Hangbu town, Shucheng County, Lu'an City, Anhui Province, China.			
Tel:+86-0564-8030526	Post Code:231300	Web: www.lvwo-energy.com	

transportation. The system external primary and secondary wires are unified interface, realizing simple and fast installation. Highly weather-resistant box can be utilized at an altitude of 3000 meters, adapting to harsh environments such as high cold, high temperature, wind and sand, etc.

### 三、 Mobile Charging System Project

#### 3.1. Components of the System

The battery charge capacity of the system is 1.49MWh, equipped with 2 sets of 360kW double-gun charging piles, and at the same time, and it supports the ground DC pile to charge the battery packs in the car compartment. A 20'GP cargo compartment (6058×2438×2896mm) is used, with 4 battery clusters (including BMS), 2 sets of convergence cabinets, 2 sets of 400KW PCS, 2 sets of 360kW charging piles, and lighting and other auxiliary systems, which are all installed inside. The topology of the energy storage system is shown in Figure 3-1:

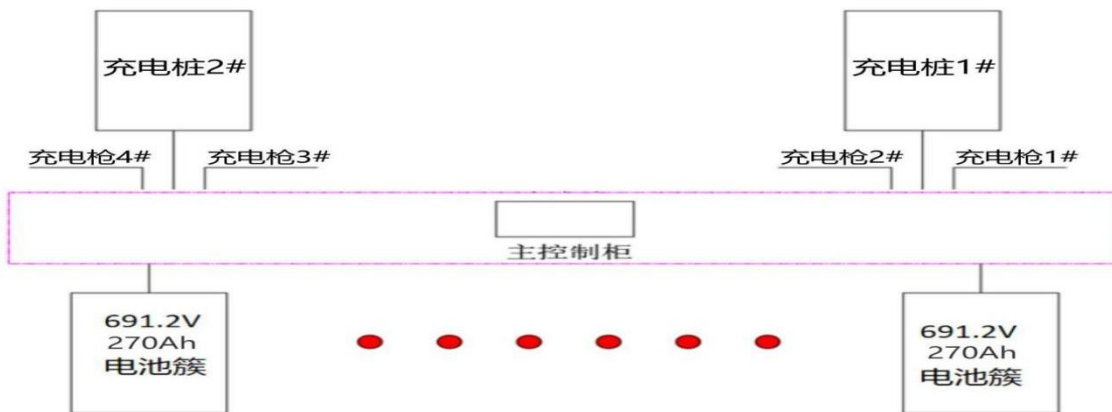

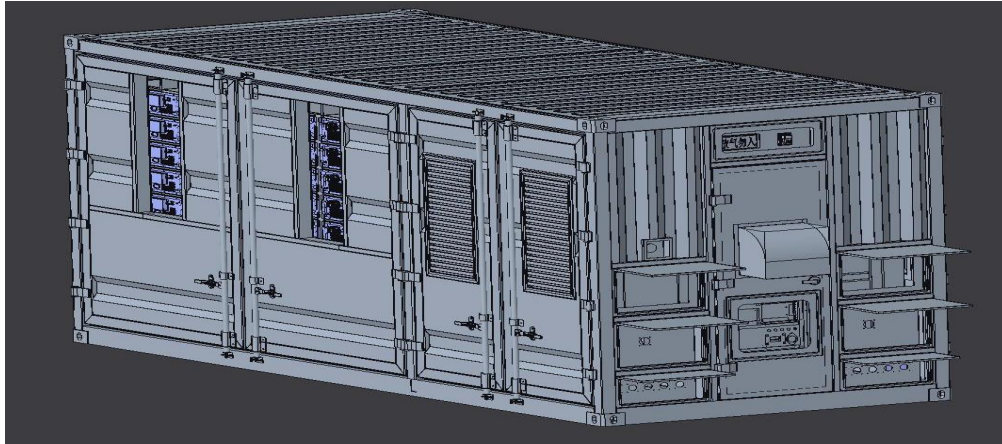

Figure 3-1 1.49MWh Mobile Charging System Topology Schematic Diagram



Figure. 1.49MWh Mobile Charging Vehicle External Diagram

### 3.2. System Configuration

The configuration of this energy storage system is characterized as follows:

- Utilizing lithium iron phosphate batteries, and it is safe, environmentally friendly, with excellent performance and long cycle life;

 <b>Lvwo</b>	<b>Specification</b>	Versions	
		Date	
		DOC No:	
Address: Address: Economic Development Zone of Hangbu town, Shucheng County, Lu'an City, Anhui Province, China.			
Tel:+86-0564-8030526	Post Code:231300	Web: www.lvwo-energy.com	

—Using its own BMS, adopting a hierarchical management strategy, and the system configuration is flexible, reliable and easy to expand and upgrade, capable of real-time monitoring of the battery system's operating parameters such as voltage, current, temperature, etc., and it is also equipped with a battery dynamic equalization management strategy, which can automatically and quickly complete battery maintenance;

—The use of proprietary intelligent thermal management control strategies optimizes the design of air ducts and heat exchanges to enhance the operational safety and service life of the energy storage system;

—The use of modular and standardized design solutions is conducive to improving product quality management, further increasing system safety and overall energy conversion efficiency, facilitating installation and maintenance.

The configuration of the main equipment is shown in Table 3-1.

Table 3-1 Configuration List for the 1.49MWh Energy Storage System.

Item	Quantity	Unit	Parameter	Notes
Cell	1728	Piece	3.2V/15Ah, 340g	
Battery Box	72	Piece	76.8V/270Ah, 155kg	1clusterand2branches, total4clusters
Host computer BMS	4	Set	Host:Guochuang	1 set per battery cluster.
Battery Box Rack	8	Set	Dimension: 1000*700*2200MM	
Convergence cabinet	2	Set	4 input channel dimensions:700*700*2200	
Charging pile	2	Set	Dual-gun 360kW Charging Pile	
PCS	2	Set	400KW	/

 <b>Lvwo</b>		<b>Specification</b>		Versions	
				Date	
				DOC No:	
Address: Address: Economic Development Zone of Hangbu town, Shucheng County, Lu'an City, Anhui Province, China.					
Tel: +86-0564-8030526		Post Code: 231300		Web: www.lvwo-energy.com	
Lighting system	1	Set	/	/	
Thermal management system	4	Set	3KW air conditioner	/	
Wiring harness	1	Set	Including complete power, control and communication harnesses (flame retardant)	/	
Auxiliary equipment	A certain number	/	/	/	

**Notes:** The above parameters are our configuration of technical parameters and the structure and external dimensions may be adjusted, while this does not affect the performance of product, part of the products parameters can be adjusted according to the requirements of different customer projects.

### 3.3. Equipment Layout

The system is integrated in a 20'GP container with 4 built-in energy storage clusters, 2 sets of control cabinets (4-channel), 2 sets of charging piles, and a set of lighting, fire-fighting, and thermal management systems. The layout is shown in Figure 3-2 below:

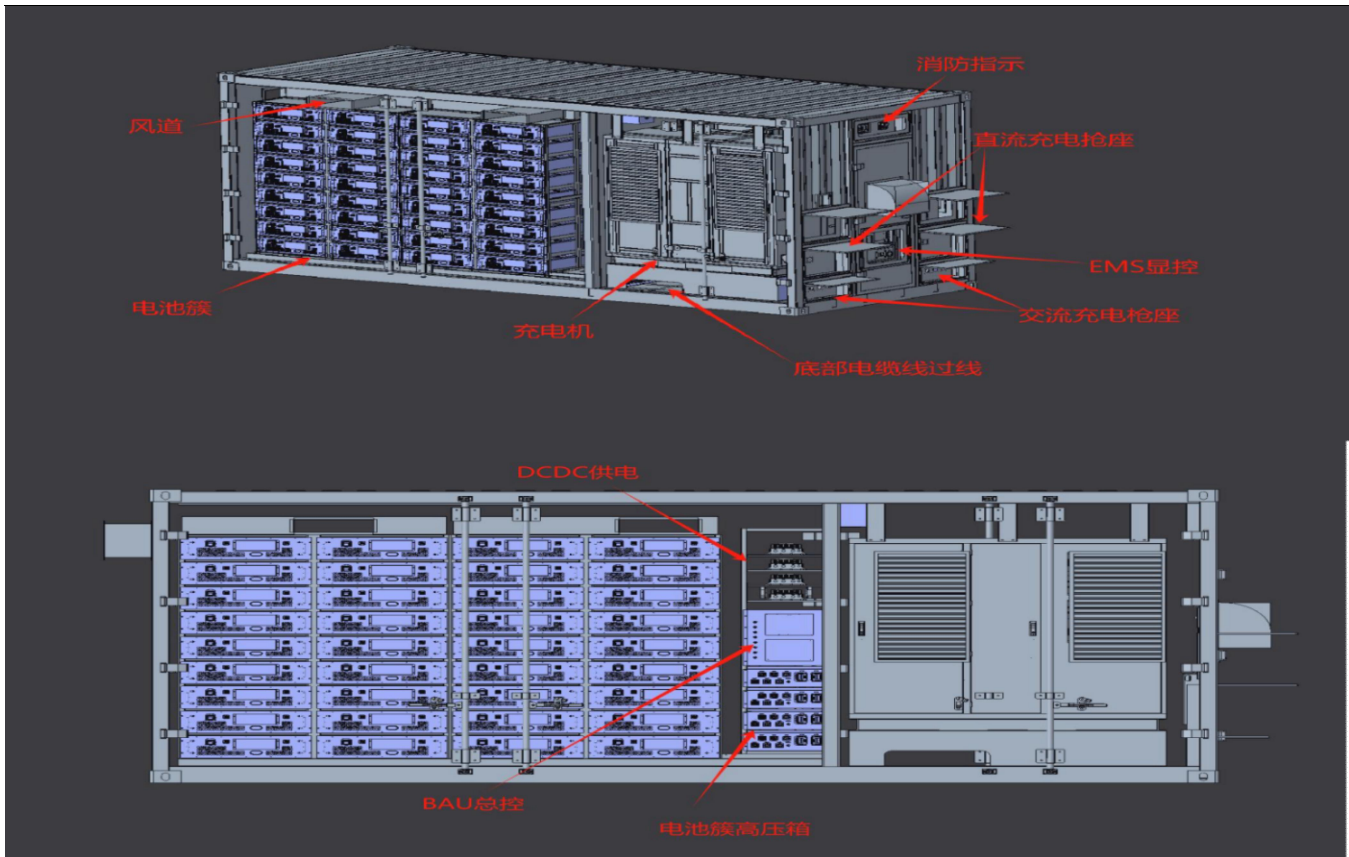

Figure 3-2 Planar Arrangement in a Cargo Compartment

## 四、 Introduction to the Main Equipment of the Mobile Charging System

### 4.1. Battery System

#### 4.1.1. Main Parameters of the Cell

This energy storage system adopts lithium iron phosphate batteries, with a single specification of 3.2V-15Ah. The specific parameters of the batteries are shown in Table 4-1 below, and the appearance of the batteries is shown in Figure 4-1.

Table 4-1 280A Cell Main Parameters

Item	Cell Parameter
Nominal voltage/capacity	3.2V
Nominal capacity	15Ah (25°C, 100%DOD, 1C)

 <b>Lvwo</b>	<b>Specification</b>	Versions	
		Date	
		DOC No:	
Address: Address: Economic Development Zone of Hangbu town, Shucheng County, Lu'an City, Anhui Province, China.			
Tel:+86-0564-8030526	Post Code:231300	Web: www.lvwo-energy.com	

Cycle life (0.3C, 25°C)	≥6000 Times (80%DOD)
Charging operating temperature	0°C~45°C
Discharging operating temperature	-10°C~60°C
Dimensions (Diameter*Height)/mm	Diameter: 38.3±0.2 mm* Height :121.5±0.3 mm
Weight/kg	0.34

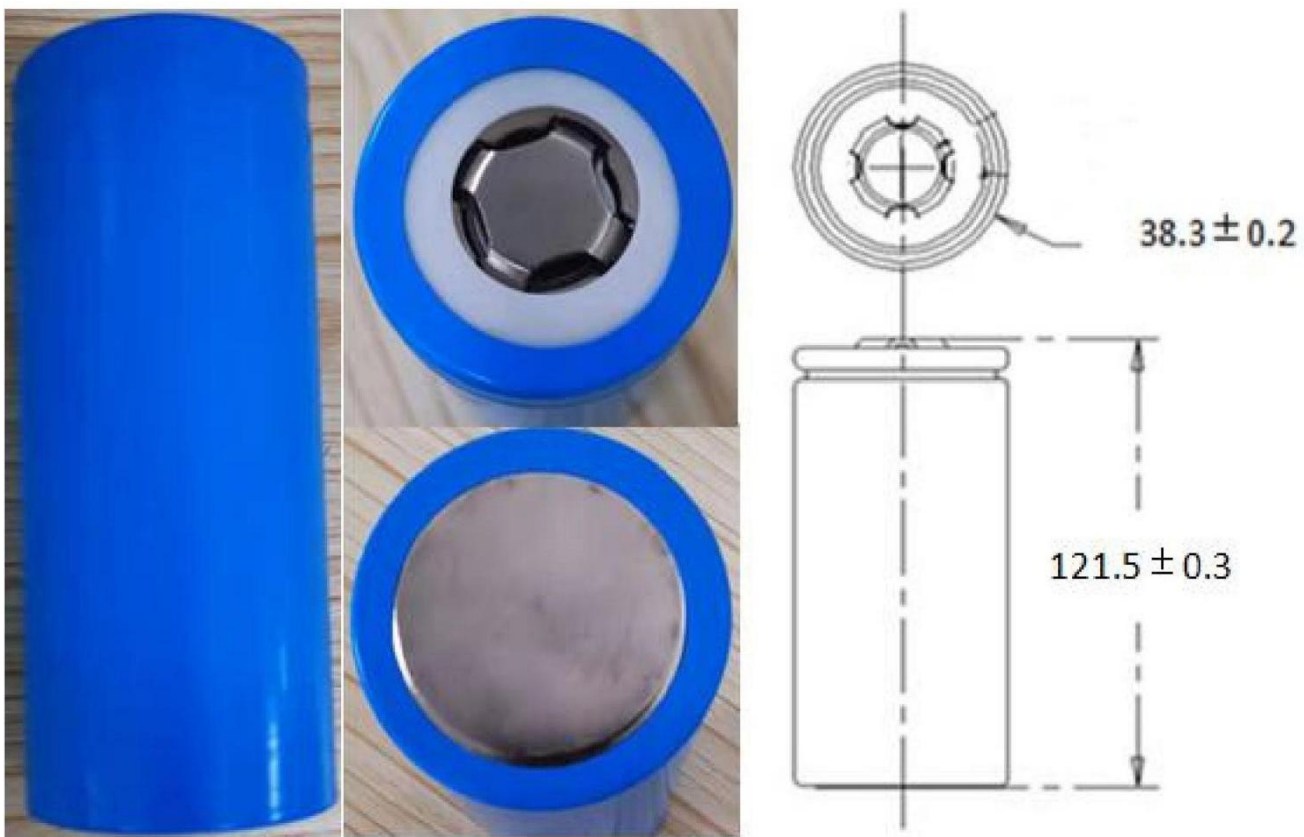

Figure 4-1 Cell Appearance

#### 4.1.2. Battery Box, Cluster and Battery System

This energy storage system adopts 24S 18P to form a battery box and 9 battery boxes are connected in series to form a battery branch. The whole energy system consists of 8 battery branches, with the total capacity of the system about 1.49MWh.

The performance of battery box, cluster, and battery system is specified in Table 4-2.

 <b>Lvwo</b>	<b>Specification</b>	<b>Versions</b>	
		<b>Date</b>	
		<b>DOC No:</b>	
<b>Address: Address: Economic Development Zone of Hangbu town, Shucheng County, Lu'an City, Anhui Province, China.</b>			
<b>Tel:+86-0564-8030526</b>	<b>Post Code:231300</b>	<b>Web: www.lvwo-energy.com</b>	

Table 4-2 Main Performance Parameters of Battery Box, Battery Cluster and Battery System

Item	Battery Box Parameter	Battery Cluster Parameter	Battery System
Rated voltage/capacity	76.8V270Ah	691.2V270Ah	691.2V2160Ah
Capacity/kWh	20.736	373.248	1492.992
Cycle life (0.25C, room temperature)	>6000 times (20-95%SOC, 20±5℃)	>6000 times (20~95%SOC, 20±5℃)	>6000 times (20~ 95%SOC, 20±5℃)
Charging operating temperature	0℃~60℃	0℃~60℃	0℃~60℃
Discharging operating temperature	-30℃~60℃	-30℃~60℃	-30℃~60℃

**Notes: The above parameters may vary due to version upgrade, so please check the physical parameters as required by the technical agreement.**

The structure of the battery module and battery box is shown in Figure 4-2.

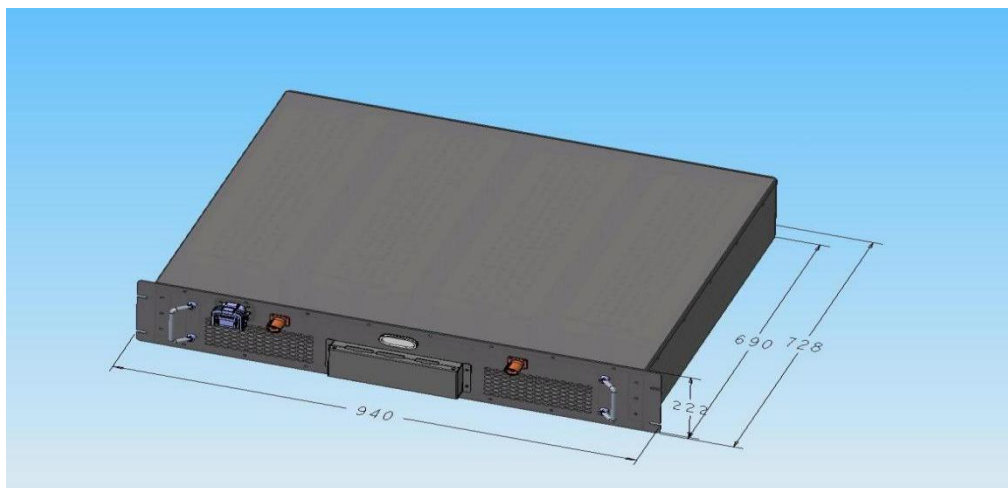

Figure 4-2 Battery Box Structure Diagram

 <b>Lvwo</b>	<h1>Specification</h1>	Versions	
		Date	
		DOC No:	
Address: Address: Economic Development Zone of Hangbu town, Shucheng County, Lu'an City, Anhui Province, China.			
Tel:+86-0564-8030526		Post Code:231300	
Web: www.lvwo-energy.com			

The total capacity of the battery system is 1.49MWh, divided into four battery clusters, and each cluster consists of a combination of 18 battery boxes with two intermediate circuit breakers on the electrical connection of the safety design. The electrical topology of the battery clusters is shown in figure 4-3.

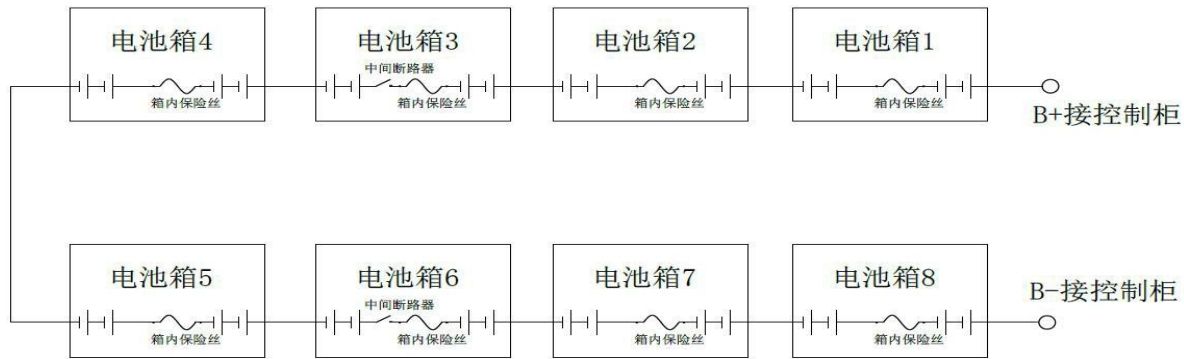

Figure 4-3 Battery Cluster Electrical Topology Diagram

Each battery cluster is connected to 2 charging piles through the control cabinet, and forms a system with a total of 4 sets of battery clusters and charging piles.

Table 4-3 System Components

Type	Model/Parameter	Mini. voltage	Max. voltage	Rated voltage	Energy /kWh	Quantity
Cell	3.2V/270Ah	2.8	3.6	3.2	0.864	31104
Battery box	18P24S	67.2	86.4	76.8	20.736	72
Battery cluster	18P216S	604.8	777.6	691.2	373.248	4
Battery system	18P216S*8	604.8	777.6	691.2	1492.992	1

 <b>Lvwo</b>	<b>Specification</b>	Versions	
		Date	
		DOC No:	
Address: Address: Economic Development Zone of Hangbu town, Shucheng County, Lu'an City, Anhui Province, China.			
Tel:+86-0564-8030526	Post Code:231300	Web: www.lvwo-energy.com	

### 4.1.3. Battery Rack Design

The energy storage battery system utilizes 2 sets of battery racks, and each set of battery racks can be installed with 4\*9=36PCS battery boxes plus 2 high-voltage boxes. The battery boxes are fixed to the battery racks by screws and pins, and the wiring harnesses are connected from the bottom of the battery racks. The structure of the battery rack is shown in Figure 4-4.

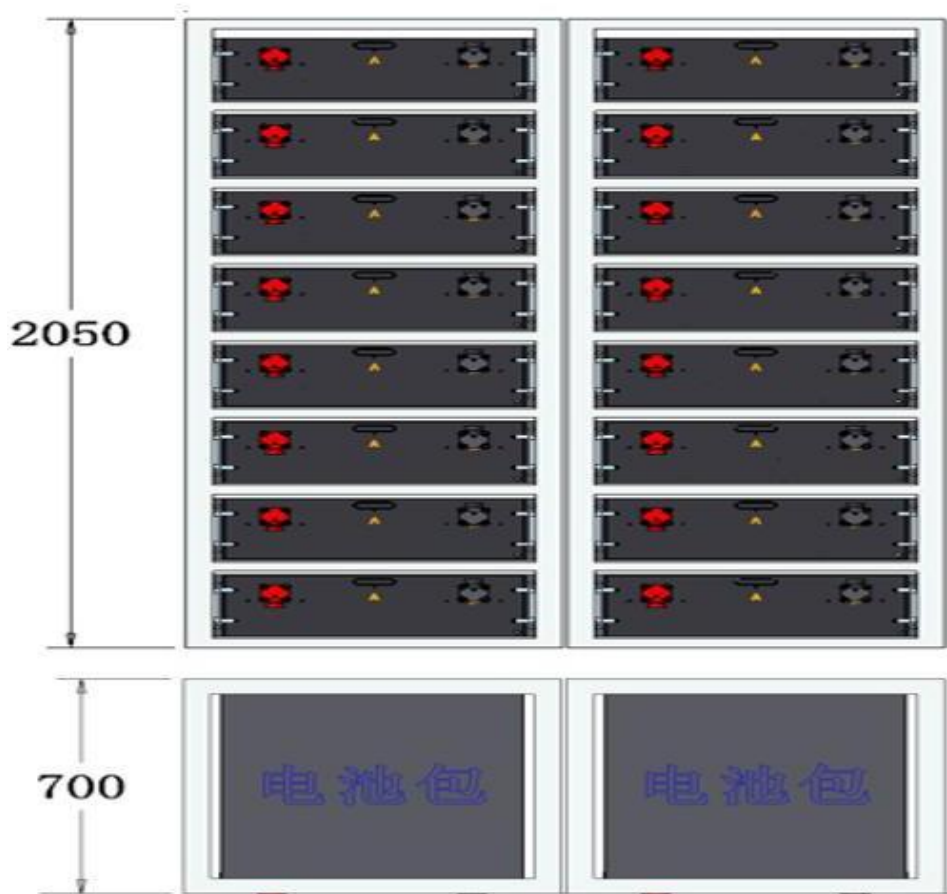

Figure 4-4 Battery Rack Structure Diagram

 <b>Lvwo</b>	<h1>Specification</h1>	Versions	
		Date	
		DOC No:	
Address: Address: Economic Development Zone of Hangbu town, Shucheng County, Lu'an City, Anhui Province, China.			
Tel:+86-0564-8030526	Post Code:231300	Web: www.lvwo-energy.com	

## 4.2. Vehicle Charging Pile

The system is equipped with two 360kW double-gun charging piles, so the system can charge four external electric vehicles at the same time. The performance parameters of the chargers are shown in Table 4-4.

### 4.2.1. Charging Pile Parameter

Table 4-4 Charging Pile Technical Parameter

Product Model	Conventional Model	360kW Dual-gun DC Charging Pile
Detailed specification	Rated power	360kW
Power cabinet	User interface	7-inch LCD color display touch screen
	Installation method	Vertical
	Alignment method	Below in and out
	Equipment dimension	1200*750*1980mm
	Input voltage	AC380V±15%
	Input frequency	45~65Hz
	Output voltage	200-750VDC
	Output Current Range	0-1188A
Charging terminal	User interface	7-inch LCD color display touch screen
	Installation method	Vertical
	Equipment method	430*201*1600mm
	Input A.C. voltage	AC220V±15%
	Input frequency	45~65Hz
	Input DC Voltage	200-750VDC
	Output DC voltage	200-750VDC
	Max. output current for a single gun	250A

	Total number of charging guns	2
	Gun-line length	5m
Electrical indicator	Measurement accuracy	Level1
	Current limit protection value	≥110%
	Stabilization voltage accuracy	≤±0.5%
	Stabilized current accuracy	≤±1%
	Ripple coefficient	≤±0.5%
	Efficiency	≥95.2%
	Power factor	≥0.99 (50% load and above)
	Harmonic content THD	≤5% (50% load and above)
Function design	Charging mode	Automatic filling/fixed power/fixed amount/fixed time
	Charging method	Charging by card / Charging by code
	Payment method	Paying by card / Paying by code
	Networking method	Ethernet 3G/4G
Safety design	Implementation standard	GB/T20234 、 GB/T18487 、 GB/T27930 、 NB/T33008、 NB/T33001
	Safety function	Charging gun temperature detection, over-voltage protection, under-voltage protection, overload protection, short-circuit protection, grounding protection, over-temperature protection, low temperature protection, insulation monitoring protection, reverse polarity protection, lightning protection, emergency stop protection, leakage protection.

Environmental Indicator	Operating temperature	-25℃~+55℃
	Operating humidity	5%~95% condensation free
	Operating altitude	<2000m
	Protection level	IP54
	Cooling method	Air cooling
	MTBF	100,000 hours

## 4.2.2. Explanation of the Operation

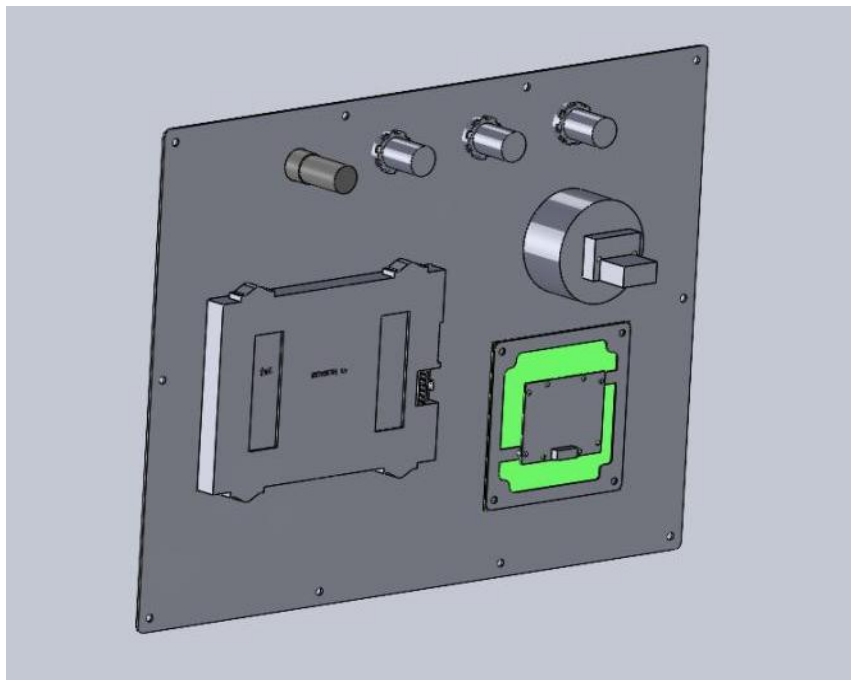

The charging pile operation panel contains the following components: power light, gun 1 operation light, gun 2 operation light, fault light, emergency stop, 7-inch display screen, card swiping machine, 4P circuit breaker (to control the auxiliary source of the charging pile)



充电桩面板进线

桩端接线

对插头

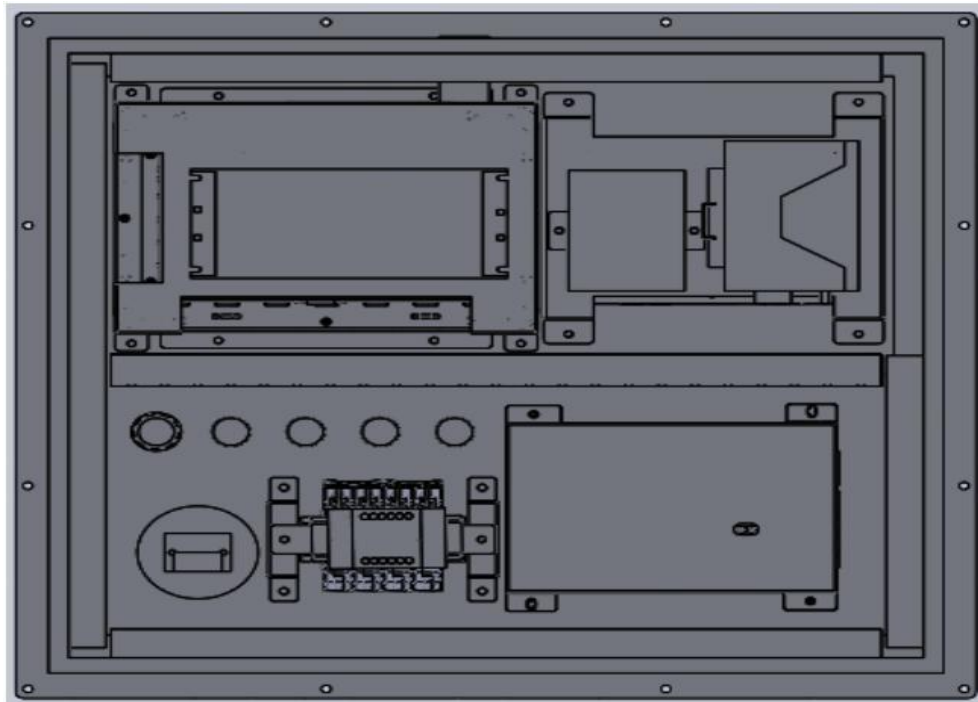

 <b>Lvwo</b>	<b>Specification</b>	Versions	
		Date	
		DOC No:	
Address: Address: Economic Development Zone of Hangbu town, Shucheng County, Lu'an City, Anhui Province, China.			
Tel:+86-0564-8030526	Post Code:231300	Web: www.lvwo-energy.com	

The components included in the energy storage operation panel are: 12V ON/OFF power supply, 10.1-inch display, switch, router, motherboard, circuit breaker switch, emergency stop, Android board, Battery Stack 1 charging/discharging, Battery Stack 2 charging/discharging, and fault light;

### 4.3 PCS Parameter

Specification KW	100
DC Side	
Max. Voltage	950V
Voltage range	615~900V (3P3L) /650V~900V(3P4L)
Input channel	1
Max. charging and discharging current	150
AC Side (grid-connected)	
Voltage range/ rated voltage	320~460/400
Wiring method	3P3L/3P4L
Rated power/ KW	100
Max. Power/ KW	110
Rated current/ A	145
Power factor	0.99
Power factor adjustment range	1 (ahead) ~ 1 (behind)
Current distortion ratio	<3% (rated power)
DC component	0.5%
Overload capability	110% Long-term
Max. discharging efficiency	>98.2%
AC side (off-grid)	
Rated output voltage/V	400
AC voltage harmonic	<3% (linear load)
Frequency/Hz	50±5Hz

 <b>Lvwo</b>	<h1>Specification</h1>	Versions	
		Date	
		DOC No:	
Address: Address: Economic Development Zone of Hangbu town, Shucheng County, Lu'an City, Anhui Province, China.			
Tel:+86-0564-8030526	Post Code:231300	Web: www.lvwo-energy.com	
AC Output Power/KW		100	
Equipment protection			
Equipped functions	Battery anti-reverse connection, DC over-current protection, AC over-current protection, AC over-voltage protection, surge protection, power grid monitoring		
System parameter			
Dimension	484*620*255mm		
Weight /KG	47		
Altitude	Deductions for >2000m		
Operating temperature	-30℃~55℃		
Storage temperature			
Humidity			
Cooling method	Intelligent air-cooling		
Protection level	IP20		
Communication interface	CAN/RS485		
Standards-compliant	GB/T 34120-2017 , GB/T 34133-2017 , EN 62477 ,EN IEC 61000		
Grid supporting	L/HVRT, active and reactive power control		
Certification	CE\CQC		

#### 4.4. Thermal Management System

Energy storage air conditioner is a kind of industrial air conditioner designed for containerized energy storage system. It adopts integrated structure and large air volume design to provide safe, reliable, energy efficient and precise temperature control solution project for containerized energy storage system. The energy storage air conditioner is available in single-cooling type, cooling and heating type to meet the application requirements of different environments.

After the air conditioner is energized, the low-voltage vapor of the coolant in the

refrigeration system is sucked in and compressed by the compressor into high-voltage vapor and discharged to the condenser, while the air sucked in by the outdoor fan flows through the condenser, taking away the heat released by the refrigerant, so that the high-voltage refrigerant vapor is condensed into a high-voltage liquid. The high voltage liquid is sprayed into the evaporator after throttling device, and evaporates under the corresponding low voltage to absorb the surrounding heat.

At the same time, the indoor fan makes the air continuously go through the fins of the evaporator for heat exchange, and sends the cooling air after exothermic to the cabinet. In this way, the air inside the cabinet continuously circulates and flows to achieve the purpose of lowering the temperature.

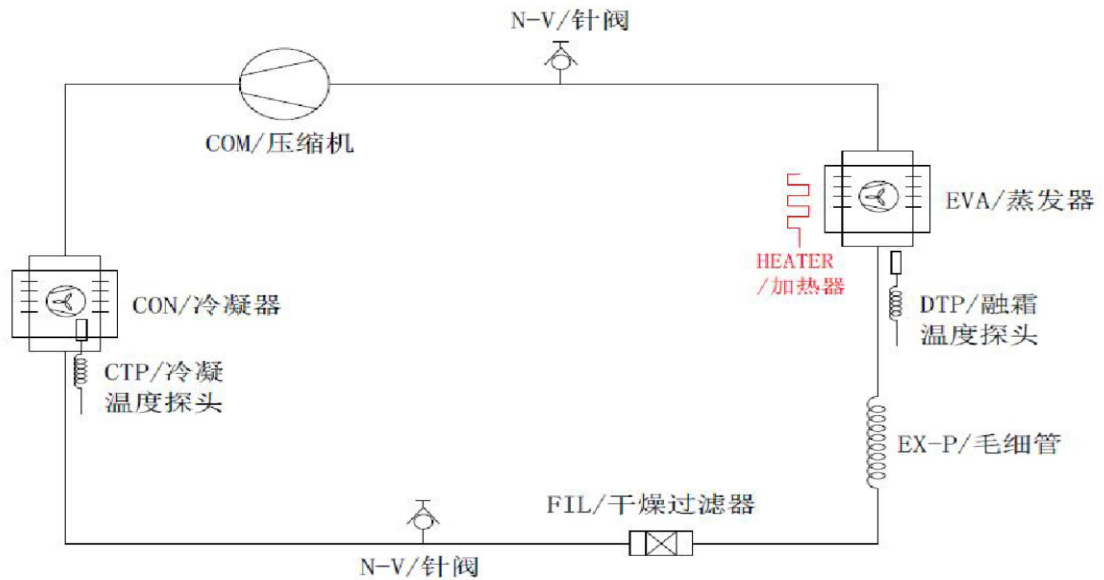

 <b>Lvwo</b>	<h1>Specification</h1>	Versions	
		Date	
		DOC No:	
Address: Address: Economic Development Zone of Hangbu town, Shucheng County, Lu'an City, Anhui Province, China.			
Tel:+86-0564-8030526	Post Code:231300	Web: www.lvwo-energy.com	

#### 4.4.1. Air Conditioner Parameter

NO.	Item	Unit	Parameter	
1	Power supply system	—	1/PE AC 220V 50Hz	1/PE AC 220V 60Hz
2	Rated power	kW	1.6/1.2	1.7/1.3
3	Rated current	A	7.1/5.4	7.4/5.7
4	Rated cooling capacity	kW	3.2	3.2
5	Heating power	kW	1	
6	Max. operating current	A	9.5	9.5
7	Internal fan air volume	m <sup>3</sup> /h	1300	1380
8	External fan air volume	m <sup>3</sup> /h	1300	1380
9	Temperature control range	°C	20~50	
10	Humidity control		Yes	
11	Usage ambient temperature	°C	-40~50	
12	Whether components are ROHS compliant.		Yes	
13	Coolant		R134a	
14	Controller type		Push-button digital controller	
15	Appearance of equipment color		RAL7035 Small wrinkle	
16	Vibration	dB (A)	70	
17	Power supply connection method		Wiring terminal	
18	Condensation water treatment method		Pooling into a catch pan and discharging through a drain pipe	
19	Installation method		Wall mounted	

 <b>Lvwo</b>	<h1>Specification</h1>	Versions	
		Date	
		DOC No:	
Address: Address: Economic Development Zone of Hangbu town, Shucheng County, Lu'an City, Anhui Province, China.			
Tel:+86-0564-8030526		Post Code:231300	Web: www.lvwo-energy.com

20	Protection level		IP55 inside and outside
21	External dimension	mm	550×276×1350
22	Net weight	kg	About 75
23	Special requirements		

## 4.5. BMS

### 4.5.1. Overview of BMS

The Energy Storage BMS utilizes 3-tier architecture that is a battery energy management architecture for small-scale energy storage systems with voltages of 1500V and below. This energy storage system architecture is capable of real-time monitoring and management of energy storage battery parameters, including high-precision SOx estimation, insulation detection, boot-loader online upgrade, thermal management, fault diagnosis, charging and discharging management, equalization, and other functions. And the interacts with screen control equipment or remote servers via Ethernet or RS485 bus are able to ensure efficient, reliable and safe operation of the energy storage system.

The project's BMS is a 3-level architecture including BMU, BCU, and BAU.

### 4.5.2. Function Description

- Supporting each pack up to 18 series of cell voltage monitoring
- Supporting each pack up to 16 series temperature monitoring
- Charging and discharging management
- Optical storage cooperative management
- Energy storage arbitrage management
- DC side current detection
- DC side voltage detection
- Insulation resistance detection
- Multi-level (cell, pack, cluster) SOx estimation value.

 <b>Lvwo</b>	<h1>Specification</h1>	Versions	
		Date	
		DOC No:	
Address: Address: Economic Development Zone of Hangbu town, Shucheng County, Lu'an City, Anhui Province, China.			
Tel:+86-0564-8030526		Post Code:231300	
Web: www.lvwo-energy.com			

- Relay control
- CAN communication
- RS485 communication
- Ethernet communication
- Three-level fault diagnosis function
- Fault recording function
- Thermal management
- Program online upgrade
- Active equalization execution
- Disconnection diagnostic function and temperature sensing troubleshooting

### 4.5.3 Battery Management Unit (BMU)

Energy storage's BMS slave control--the BMU product is a slave control acquisition product for 1500V voltage and below energy storage systems. The product is installed within the battery pack, and can sample the cell voltage and temperature information, and the product can realize the voltage and temperature acquisition harness status. In addition, this product can also fulfill the information acquisition of fan control and fire-fighting in the pack and transmit the data to the master control BCU through CAN communication. The picture is shown in 7-1.



Figure 7-1 BMU Image

 <b>Lvwo</b>	<b>Specification</b>	Versions	
		Date	
		DOC No:	
Address: Address: Economic Development Zone of Hangbu town, Shucheng County, Lu'an City, Anhui Province, China.			
Tel:+86-0564-8030526	Post Code:231300	Web: www.lvwo-energy.com	

The BMU has the following features according to the system needs:

- ✧ Relay control
- ✧ CAN communication
- ✧ Thermal management
- ✧ Program online upgrade
- ✧ Cell temperature monitoring
- ✧ Cell voltage monitoring
- ✧ Active equalization execution

The specific parameters are shown in Table 7-1

Table 7-1 BMU Parameter Table

<b>Level 1 BMS - Slave BMU</b>		
Operating voltage	12V DC~36V DC(Externally powered/self-powered)	
Operating ambient temperature	-20℃~50℃	
Operating humidity	5%~90%	
Power supply	DC12V/24V	
Digital signal detection	4-channel	
Digital signal output	4 channels	
Voltage acquisition	Acquisition channel	Up to 54 channels and backward compatible
	Acquisition range	1V~5V
	Acquisition precision	Tolerance: ±5mV
	Acquisition cycle	≤100ms
Temperature acquisition	Acquisition channel	Max.18channels
	Acquisition range	-40℃~+125℃

 <b>Lvwo</b>	<b>Specification</b>		Versions	
			Date	
			DOC No:	
Address: Address: Economic Development Zone of Hangbu town, Shucheng County, Lu'an City, Anhui Province, China.				
Tel:+86-0564-8030526		Post Code:231300		Web: www.lvwo-energy.com
	Acquisition precision	-40℃~-30℃, tolerance : ±2℃		
		-30℃~+60℃, tolerance : ±1℃		
		+60℃~+125℃, tolerance: ±2℃		
	Acquisition cycle	≤100ms		
Balance	Turning-on condition	Following the strategy		
	Balanced current	100mA		
Relay control channel	Control channel	4 channels (3 channels active and 1 channel passive)		
	Driving voltage	24V DC		
	Driving force	1A		
Optocoupler control channel	1 active output, no load capability, only DO signal output available			
CAN communication	communication channel quantity	1 channel (Communication with secondary BMS)		

#### 4.5.4. Battery Cluster Management Unit (BCU)

##### Introduction to BCU modules

Battery Cluster Management Unit (BCU) is the core component of the energy storage BMS and it is the bridge between the battery pack and the external equipment, which determines the utilization rate of the battery, and its performance of great importance to the cost and safety performance of the energy storage system. The BCU is generally placed in the high voltage box of the battery cluster to realize the real-time monitoring of the total voltage, total current, insulation resistance and internal temperature of the high voltage box of the battery cluster.

At the same time, it summarizes the information of voltage and temperature of the cells in

the cluster, so as to realize the SOC/SOH estimation of the cluster, execute the judgment of equalization strategy and the fault diagnosis and alarm of the cells, and to fulfill the functions of in-situ protection and relay control of the cluster according to the information of the cell faults.

Finally, it interacts with MPS, EMS (secondary architecture), BAU and other devices through CAN/RS485 communication interfaces. When the battery cluster has serious over-voltage, under-voltage, over-current (short-circuit), over-temperature, leakage (insulation) and other abnormal faults, the BCU can effectively control the switching on and off of the battery cluster, avoiding happening overcharge, over-discharge, over-temperature, over-current of the batteries, and guaranteeing the high efficiency, reliability, and safe operation of the energy storage system.

The design adopts a highly reliable control chip, and the hardware architecture utilizes the SBC+MCU+ADC+HSD integration project to achieve high-precision synchronous acquisition of total voltage and current within the battery cluster.

BCU Module Parameter Specifications

Parameter	Description	Technical indicator				Remarks
		Min.	Type	Max.	Unit	
Operating voltage	System operating voltage range	9	12/2	32	V	
Operating current	System operating current at 24V	-	150	200	mA	No external loading
Static current	System dormancy current at 24V	-	-	1	mA	
System wake-up	Hard-wire enables the control level	9	12/2	32	V	
Communication	Interface channel	-	-	3	Channel	CAN1 and CAN3 have built-in 120Ω matching resistor, CAN2 has no 120Ω matching resistor, and CAN1 is non-isolated

	Communications rate	125	250	500	Kbit	Depending on project configuration
RS485 communication	Interface channel	-	-	2	Channel	Built-in 120Ω matching resistance
	Communication rate	9600	1920	1152	bps	Depending on project configuration
Cluster total voltage acquisition	Acquisition channel	-	-	2	Channel	Expandable 1 channel
	Acquisition range	0	-	1500	V	
	Acquisition tolerance	-	-	±0.	F.S	
Shunt current acquisition	Full scale acquisition range	-1000	-	1000	A	Depending on shunt range
	Full scale acquisition tolerance	-	-	±0.	F.S	Excluding the shunt's own tolerance
	Small-range acquisition range	-50	-	50	A	Depending on shunt range
	Small-range acquisition tolerance	-	-	±0.	A	Excluding the shunt's own tolerance
Hall current acquisition	Hall sensor power supply voltage	4.8	5	5.2	V	Voltage Hall sensors
	Full scale acquisition range	-500	-	500	A	Depending on Hall sensor range
	Full scale acquisition tolerance	-	-	±0.	F.S	Excluding Hall sensor's own tolerance

	Small-range acquisition range	-75	-	75	A	Depending on Hall sensor range
	Small-range acquisition tolerance	-	-	±1	A	Excluding Hall sensor's own tolerance
Battery cluster total	Total negative relay sticking diagnosis	-	-	1	Channel	
negative relay sticking diagnosis	Total negative relay normal diagnostic voltage	2	2.5	3	V	
	Total negative relay sticking diagnostic voltage	0	0.5	1	V	
Temperature acquisition	Acquisition channel	-	-	6	Channel	Default R25=10K,
	Acquisition range	-40	-	125	°C	
	Acquisition tolerance	-	±1	±2	°C	-20 ~ 65°C range, tolerance ≤±
Insulation resistance acquisition	Full scale acquisition range	0.00	-	20	MΩ	
	Full scale acquisition tolerance	-	-	±20	F.S	
	Small-range acquisition range	5	-	50	kΩ	
	Small range acquisition tolerance	-	-	±10	kΩ	
Drive control	Control channel	-	-	10	Channel	8-channel HSD outputs and 2-channel LSD outputs
	Continuous current carrying capacity at 24V	-	-	1	A	

	Transient current-carrying capability at 24V	-	-	5	A	100ms
Digital DO output	Control channel	-	-	1	Channel	Supporting high-level and PWM, integrated fault diagnostics, and low 2V operating voltage
Digital DI detection	Detection channel	-	-	8	Channel	6 high level inputs, and 2 low level inputs
	High level threshold	6	12/2	32	V	
	Low level threshold	0	-	1	V	
AI acquisition	Acquisition channel	-	-	1	channel	
	Acquisition range	0	-	32	V	
	Acquisition range	-	-	±0.	V	
	Control channel	-	-	2	channel	1 mechanical relay (dry contact 2), 1 solid state relay (dry contact 3), all isolated control
	Mechanical relay continuous current-carrying capacity	-	-	2	A	30V DC/250V AC with no load shedding possible
	Solid state relay continuous current carrying capacity	-	-	0.5	A	48V DC

 <b>Lvwo</b>	<h1>Specification</h1>	Versions	
		Date	
		DOC No:	
Address: Economic Development Zone of Hangbu town, Shucheng County, Lu'an City, Anhui Province, China.			
Tel:+86-0564-8030526	Post Code:231300	Web: www.lvwo-energy.com	

SOX Estimation	SOC estimation	-	-	±5	%	Detailed cell data required
	SOH estimation	-	-	±5	%	
	SOE estimation	-	-	±5	%	
	DCR estimation	-	-	±10	%	
Data storage	Event records quantity	-	-	120 0	Pieces	
	Real-time data storage	-	-	1	Year	60s/piece
Big data storage	Max. storage space	-	16	32	GB	Inserting TF card for data storage
Real-time clock	Beijing time tolerance	-	-	1	min	
Auto addressing	Supporting CSU module addressing and BCU addressing itself	-	-	-	-	BAU/BCU sends addressing message
CSU power supply enable	Enabling control level	9	12/2	32	V	
Electrical insulation	1000V/DC below	100	-	-	MΩ	No breakdown or flash-over of the battery cluster's high-voltage side acquisition interface terminal and MCU side interface terminal or shell
Voltage resistance	≥2U+1000V/DC	-	-	430 0	V	
	60s Leakage current	-	-	2	mA	No breakdown or flash-over of the battery cluster's high-voltage side acquisition interface

						terminal and MCU side interface terminal or shell
--	--	--	--	--	--	---

---

#### 4.5.5. Battery Array Management Unit (BAU)

The intelligent master control unit of energy storage's BMS is a battery management master control unit for three-level energy storage architectures. It summarizes and displays the data of cells, packs and clusters of  $\leq 5$ WM energy storage systems; performing SOX (SOH/SOC) calculations for battery stacks; realizing information monitoring and control with MPS, EMS and fire-fighting systems; and supporting the General Electricity Co-ordination System (GECS) and remote dispatching; allowing large-capacity data storage and EMS energy management of local system according to the system architecture.

The BCU is designed to be characterized according to the stated functional needs:

- ✧ Charging and discharging management
- ✧ Photovoltaic storage synergy management
- ✧ Energy storage arbitrage management
- ✧ Estimation of SOC for four levels (Cell, pack, cluster and stack)
- ✧ Estimation of SOH for four levels (Cell, pack, cluster and stack)
- ✧ Estimation of nominal capacity for four levels (Cell, pack, cluster and stack).
- ✧ Relay control
- ✧ CAN communication
- ✧ RS485 communication
- ✧ Ethernet communication
- ✧ 4G/GNSS communication (optional)
- ✧ DTU communication
- ✧ Four-level fault diagnosis function
- ✧ Fault recording function
- ✧ Program online upgrade
- ✧ Battery health diagnosis
- ✧ Intelligent operation and maintenance (optional)
- ✧ Supporting general power protocols such as IEC61850 and IEC104 (optional)

 <b>Lvwo</b>	<b>Specification</b>	Versions	
		Date	
		DOC No:	
Address: Address: Economic Development Zone of Hangbu town, Shucheng County, Lu'an City, Anhui Province, China.			
Tel:+86-0564-8030526		Post Code:231300	
Web: www.lvwo-energy.com			

The specific parameters are shown in Table 7-2.

**Table 7-2 BAU Parameter Table**

<b>Energy Storage Intelligent Master Control Unit BAU</b>		
Operating voltage	12V DC~36V DC(External power supply )	
Operating ambient temperature	-20℃~50℃	
Operating humidity	5%~90%	
Power supply	DC12V/24V	
Digital signal detection	16-channel	
Digital signal output	16-channel	
Communication interface	RS485	4-channel (with isolation)
	RS232	1 channel (with isolation)
	Ethernet	2-channel
	CAN	2-channel
	4G	1 channel
Human-computer interaction (HMI)	10.1 inch capacitive screen	
Large capacity storage	128G	

 <b>Lvwo</b>	<h1>Specification</h1>	Versions	
		Date	
		DOC No:	
Address: Address: Economic Development Zone of Hangbu town, Shucheng County, Lu'an City, Anhui Province, China.			
Tel:+86-0564-8030526	Post Code:231300	Web: <a href="http://www.lvwo-energy.com">www.lvwo-energy.com</a>	

## 4.6. Fire-fighting System

### 4.6.1 Product Profile

1、 The fire-fighting system consists of a cabinet-type perfluorohexanone fire extinguishing device containing perfluorohexanone, fire extinguishing agent storage bottles, container valves, actuators, high-voltage hoses, pressure signals, nozzles, cabinets, piping fittings, etc. It is mainly used for spraying agents to achieve the effect of fire-fighting in time when fire occurs.

2、 The gas control system consists of a gas extinguishing system control panel, smoke detectors, temperature detectors, audible and visual fire alarms, gas release alarms, emergency start/stop buttons, etc. It is mainly used for detection, alarm and feedback.

3、 Explosion-proof fan ventilation system consists of ventilating electric louvers, energy storage and explosion relief fan (electric louvers + explosion-proof fan), which, together with the gas detector and the alarm host, constitute the ventilation system of the energy storage container to prevent combustible gases from accumulating and reaching the explosion concentration, thus generating the risk of explosion.

4、 The on-line carbon monoxide detector is suitable for detecting carbon monoxide concentration in various environments. It adopts electrochemical sensor and micro-controller technology, with fast response speed, high measurement accuracy, good stability and repeatability.

5、 The on-line hydrogen detector is suitable for detecting hydrogen concentration in various environments. It adopts catalytic combustion sensor and micro-controller technology, with fast response speed, high measurement accuracy, good stability and repeatability.

6、 Mechanical pressure relief port: An opening for relieving pressure in a protective area to prevent the pressure in the area from exceeding the allowable pressure when the extinguishing agent is being discharged.

## 4.6.2 Fire Extinguishing Project

1、Perfluorohexanone fire extinguishing system: It is equipped with a set of perfluorohexanone fire extinguishing device, the nozzles are extended to the top of 8 clusters through fire-fighting pipelines. When the fire extinguishing system is set to automatic mode, in the working state, after the smoke and temperature detectors alarm at the same time, the gas fire extinguishing controller will activate the audible and visual alarms to give out the audible and visual alarms and delay for 30s to give the command to extinguish the fire, and then the fire extinguishing system will work in accordance with the following procedures. (1) Linkage closure of the opening and closing device, ventilator and other equipment. (2) After a delay of 30s, start the solenoid valve, open the cylinder head valve to release perfluorohexanone extinguishing agent to extinguish the fire, in the opening of the solenoid valve to release the extinguishing agent through the fire-fighting pipeline and spray nozzle sprayed on the designated protective area at the same time, the deflating indicator light synchronization, while forbidding the personnel entering the protective area. And at the same time, the feedback is sent to BMS through RS485 communication. When the fire extinguishing system is set to manual mode, and if the operator dials the control key of the gas extinguishing controller to the “Manual” position, the gas extinguishing controller will start the acoustic and visual alarm when the smoke and temperature sensors alarm at the same time, sound and light alarm will be issued, while the fire extinguishing device will not be started.

The operator observes whether there is fire at the scene, if there is any fire, press the “Emergency Start” button on the gas fire extinguishing controller or rotate the key on the manual control box outside the door of the protection area to the “Start” position to start the fire extinguishing device. When the solenoid valve is activated after a delay of 30s, the head valve of the storage bottle will be opened to release the perfluorohexanone fire extinguishing agent to fight the fire. When the solenoid valve is opened to release the fire extinguishing agent through the fire-fighting pipeline and the nozzle is sprayed on the designated protective area, the deflating indicator will light up synchronously, and it will prohibit the personnel from entering into the protective area.

 <b>LVWO</b>	<b>Specification</b>	Versions	
		Date	
		DOC No:	
Address: Address: Economic Development Zone of Hangbu town, Shucheng County, Lu'an City, Anhui Province, China.			
Tel:+86-0564-8030526	Post Code:231300	Web: www.lvwo-energy.com	

And, at the same time through the RS485 communication, the feedback is sent to the BMS. When the operator observes that there is no fire at the scene and there is no need to start the fire extinguishing device, the operator can press the “ Stop” button on the gas fire extinguishing controller or rotate the key on the manual control box outside the door of the protected area to the “Stop” position to stop the fire extinguishing device from starting and no feedback. The device will not be activated and no feedback will be given.

2、 Explosion-proof fan ventilation and exhaust system:It is equipped with a set of explosion-proof fan ventilation and exhaust system, the controller. Host receives the alarm signal from the gas detector and sends a signal to the ventilation and exhaust system. When the concentration of combustible gas is higher than the threshold, the electric louvers of the exhaust fan are opened, the explosion-proof fan is opened, and the electric louvers of the ventilation are opened to exhaust the combustible gas in the energy storage box. And, the controller host receives the signal and closes the ventilation system automatically.

3、 Carbon monoxide detector: It is equipped with a carbon monoxide detector. When the concentration of carbon monoxide exceeds the set value detected electrochemically in the charging vehicle, the LCD liquid crystal display screen will show the gas concentration clearly and intuitively, and the signal will be outputted to the gas control alarm (at the same time, the gas control alarm screen can show the on-site situation), the gas control alarm will generate audible and visual alarm, and meanwhile the information feedback will be sent to the BMS through RS485 communication.

4、 Hydrogen detector: It is equipped with a hydrogen detector, when the hydrogen concentration exceeds the set value in the charging vehicle through the catalytic combustion principle, the LCD liquid crystal display will clearly and intuitively display the gas concentration and output the signal to the gas control alarm (at the same time, the gas control alarm screen can display the on-site situation), and then the gas control alarm can generate sound and light alarms and the information will simultaneously be fed to the BMS through the RS485 communication.

5、 Mechanical pressure relief port: In case of fire, when the pressure in the protection area is greater than 1200Pa and the agent is sprayed, the pressure relief device will open

 <b>LVWO</b>	<h1>Specification</h1>	Versions	
		Date	
		DOC No:	
Address: Address: Economic Development Zone of Hangbu town, Shucheng County, Lu'an City, Anhui Province, China.			
Tel: +86-0564-8030526		Post Code: 231300	
		Web: www.lvwo-energy.com	

automatically to discharge the excess pressure while the pressure relief port will close automatically when the pressure in the pressure relief port is less than 1200Pa.

**Design project:**

### 4.7. System Communication Topology Diagram

The system consists of four independent subsystems. The communication topology of each of these subsystems is shown in Figure 4-8.

